

Brought
Superior

The World's Finest Machine

DAGGER





LAWRENCE'S BLADE

Brough Superior's modern range is being expanded for 2023 with a new roadster named Dagger, which takes the brand into a new dynamic while retaining its traditional extreme build quality.

After the Lawrence released in 2020 and the Nefud which appeared in 2021, the new roadster also refers to the legendary character of Lawrence of Arabia. This was the weapon worn on his belt (janbiya in Arabic) that Lawrence was given in 1917 after the capture of Aqaba, the climax of the Arab Revolt that made him world famous. Symbolically, the dagger, which belonged to a collector far from Britain, returned to the National Army Museum in London just as the Brough Superior brand began its modern era.

Reflecting the British treasure, the Dagger appears as a sharp, subtly textured roadster, with a satin finish reflecting the care taken to finish it at the Saint-jean factory near Toulouse. The 1000cc twin-cylinder engine was designed and assembled there, with increased power and torque and now fulfilling Euro 5 standards.

The two-in-one exhaust system with an exhaust valve was also designed to match the Dagger's muscular and slender lines, with sharp edges that refer to the famous Lawrence blade. The prominent radiator, as on the Aston Martin AMB-001 developed by Brough Superior, completes the feeling of power emanating from these new volumes.

With this beauty called Dagger, Brough Superior achieved a bike more incisive than ever, thanks to a geometry that allows for more liveliness with more curved handlebars and 17 x 17 wheels, the first time this has been done on a modern Brough Superior. The classic range (S.S. 100, Anniversary) uses 18 x 18 wheels, while the other machines in the modern range, the Lawrence and the Nefud, adopt a 19" wheel at the front and 17 at the rear for a mixed ride.

As fiery and impetuous as Lawrence's campaigns, the Dagger is a major part of the Brough Superior adventure.

LAME DE LAWRENCE

La gamme moderne de Brough Superior s'étend pour 2023 avec un nouveau roadster baptisé Dagger, qui inscrit la marque dans une nouvelle dynamique tout en conservant sa traditionnelle qualité extrême de fabrication.

Après la Lawrence sortie en 2020 et la Nefud apparue en 2021, le nouveau roadster fait lui aussi référence au légendaire personnage de Lawrence d'Arabie, Dagger signifiant « dague » ou « poignard » dans la langue de son pays natal. C'est cette arme portée à la ceinture (janbiya en arabe) que Lawrence s'est vu remettre en 1917 après la prise d'Aqaba, point culminant de la Révolte arabe qui l'a rendu célèbre. Comme un symbole, c'est au moment où la marque Brough Superior a débuté son ère moderne que la dague, qui appartenait à un collectionneur lointain de Grande-Bretagne, est revenue au National Army Museum de Londres.

A l'image du trésor britannique, le Dagger apparaît comme un roadster affûté aux textures subtiles, avec un aspect satiné témoignant du soin apporté à sa finition dans l'usine de Saint-jean, près de Toulouse. C'est là aussi qu'a été conçu et assemblé le bicylindre de 1000 cm³ disposant de davantage de coffre (puissance et couple en hausse) et répondant désormais aux normes Euro 5.

L'échappement deux-en-un disposant d'une valve à l'échappement a lui aussi fait l'objet d'un design correspondant parfaitement aux lignes musculeuses et élancées du Dagger, dont les arêtes acérées renvoient à la fameuse lame de Lawrence. La mise en valeur de l'imposant radiateur, comme sur l'Aston Martin AMB-001 développée par Brough Superior, parachève la sensation de puissance dégagée par ces nouveaux volumes.

Avec cette merveille nommée Dagger, Brough Superior réalise une moto plus incisive que jamais, grâce à une géométrie permettant davantage de vivacité avec un guidon plus cintré et des roues de 17 x 17, une première sur une Brough Superior moderne. La gamme classique (S.S. 100, Anniversary) a en effet recours à des roues de 18 x 18, quand les autres machines de la gamme moderne, la Lawrence et la Nefud, adoptent une roue de 19 pouces à l'avant et 17 à l'arrière pour un comportement mixte.

Aussi fougueux et impétueux que les campagnes de Lawrence, le Dagger se taille une part de choix dans l'aventure Brough Superior.





DAGGER





TECHNICAL SPECIFICATIONS

ENGINE

Engine	997cc watercooled dohc 88° V-twin four-stroke with four valves per cylinder and composite chain / gear cam drive
Dimensions	94 mm x 71.8 mm
Power	102bhp (75kW) @9600rpm Euro 5 Homologation
Maximum torque	87Nm (64lb-ft) @7300rpm
Compression ratio	11 : 1
Fuel / Ignition system	Electronic fuel injection with Synerject ECU and 2 x 50 mm Synerject throttle bodies, each with a single injector
Tank capacity	17 L
Gearbox	6-speed
Clutch	Multiplate oil-bath clutch with hydraulic operation

CHASSIS

Frame type	Machined Titanium frame with Titanium subframe and triangles
Front suspension	Fior-type fork CNC machined from aluminium solid with twin articulated triangular Titanium links and Pre load and rebound adjustable monoshock with 120mm travel
Rear suspension	Swingarm CNC machined from aluminium solid pivoting in engine crankcases, with monoshock adjustable for preload and rebound damping and progressive rate link with 130mm travel
Head angle / Trail	24.6° with 108.3mm trail via 37.1mm fork offset
Front brake	2 x 320mm Beringer Stainless Steel discs with 2 x two-piston Beringer radial calipers
Rear brake	1 x 230mm Beringer Stainless Steel disc with 1 x two-piston Beringer radial caliper
Wheels	Machined aluminium wheels (7 spokes)
Front tyre	120/70 - 17" on 3.50 inches
Rear tyre	200/55 - 17" on 6.25 inches
Weight / Distribution	200 Kg (440 lb) split 50/50%

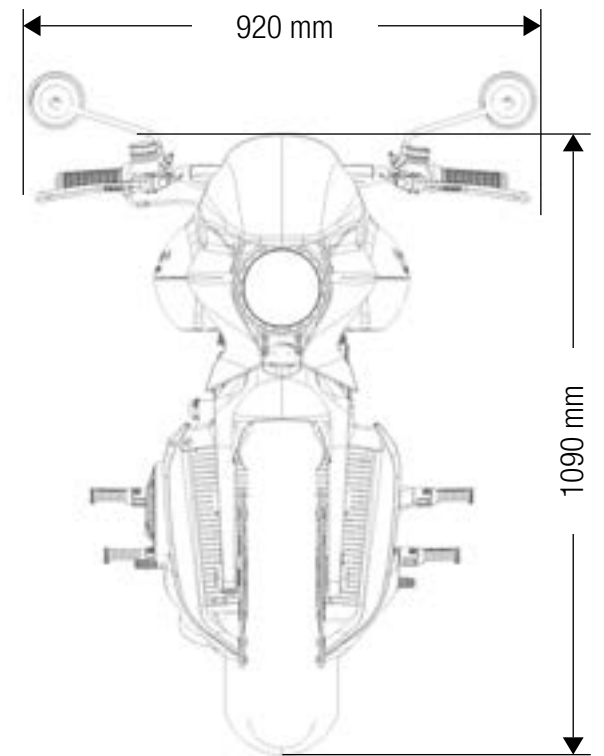
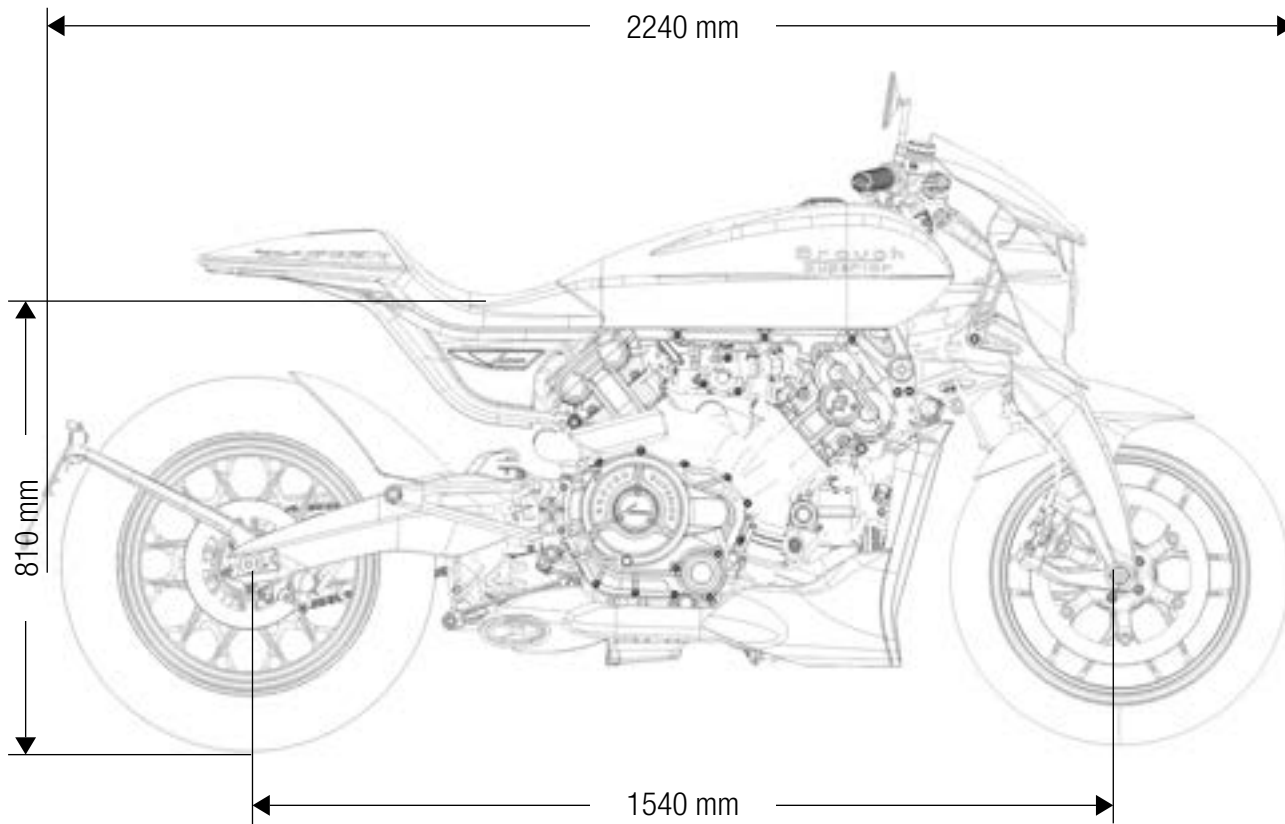



A close-up, low-angle photograph of a motorcycle's rear wheel and fender. The wheel features a multi-spoke alloy design. The fender is dark and has a small, metallic, hook-like detail. The background is a blurred, industrial-looking structure with a grid pattern.

NOTICES

Visuals: Photos and drawings

Some motorcycles are equipped with optional elements for racetrack use only. Additional options may be available at an additional cost. They may not be included in this brochure. Feel free to ask for more information.

Updates

In a process of constant improvement, both in terms of products (design, manufacturing, etc.) and safety, Brough Superior Motorcycles reserves the right to make changes to its product at any time, without notice. All specifications, illustrations, details and diagrams contained in this brochure are based on information available as of 15/06/2022.

Due to the limitations of printing process, visuals colors (if any) are not contractual.

Some images used for staging our product are not contractual.

Acceleration and speed rates may vary from those in the documentation depending on country specificities or product updates that may have occurred after documentation printing.

If you have any questions, please do not hesitate to contact your authorized Brough Superior Motorcycles contact person or feel free to contact us directly.

Copyright and other intellectual property rights

Copyright Brough Superior Motorcycles 2022. Do not reproduce or transmit without the express permission of Brough Superior Motorcycles. The Brough Superior name and logo are registered trademarks owned by Brough Superior Motorcycles Ltd and Brough Superior Motorcycles sas.

Company details

Brough Superior Motorcycles Head Office

20 rue Jean Monnet,

31240 Saint-Jean,

France.

Telephone +33 (0) 562 892 460

VAT number FR1801344318

S.S. 100



Salt Racer



PENDINE



Bert Le Vack



Karslake



Dixon



ANNIVERSARY
100
1919 1919 2019





BROUGH SUPERIOR MOTORCYCLES SAS

✉ 20 RUE JEAN MONNET

31240 SAINT JEAN (FRANCE)

☎ +33 (0) 562 892 460

www.broughsuperiormotorcycles.com